 <p>HEALTH, SAFETY & ENVIRONMENTAL MANUAL</p>	11.6 Formwork and Falsework Program				
	Initial HIRA Score:	15	Residual HIRA Score:	10	Critical Task: Yes
	Procedure(s): 12.11.6				
	Revision Number: R0		Number of Pages: 27		
	Revision Date:	Approval Date: 10/01/2024	Effective Date: 10/01/2024	SIGNATURE: 	

Formwork and Falsework

DEFINITIONS

The following definitions are used in the forming industry. Some terms may be used by other trades as well, but their meanings may be different from these depending upon the application.

Falsework: in relation to a form or structure, means the structural supports and bracing used to support all or part of the form or structure until the concrete is poured and is strong enough to support loads.

Flying Formwork: a designed floor formwork system that can be hoisted between levels as a unit.

Forms: the molds into which concrete or another material is poured.

Formwork: a system of forms connected together.

Gangforms: large panels designed to be hoisted as a unit, and to be erected, stripped, and re-used.

Knock-down Forms: traditional formwork supported by falsework and shoring, assembled from bulk materials, used once, and then dismantled.

Panels: sections of form intended to be connected together.

Sheathing: the material directly supported by wales, and against which concrete is to be placed.

Specialty Formwork: designed specifically for a particular structure or placing technique.

Struts: vertical members of shoring that directly resist pressure from wales.



Wales: horizontal members of shoring that are placed against sheathing to directly resist pressure from the sheathing.

PROCEDURE

In most cases, the formwork required for concrete construction is built by formworkers or engineered. Shoring and bracing support the forms that contain the wet concrete. Formwork must also support the temporary weight of material such as bundles of reinforcing steel and live loads of workers and equipment.

There are three stages in formwork operations:

1. Assembly and erection
2. Concrete placement
3. Stripping and dismantling.

 HEALTH, SAFETY & ENVIRONMENTAL MANUAL	11.6 Formwork and Falsework Program				
	Initial HIRA Score:	15	Residual HIRA Score:	10	Critical Task: Yes
	Procedure(s): 12.11.6				
	Revision Number: R0		Number of Pages: 27		
	Revision Date:	Approval Date: 10/01/2024	Effective Date: 10/01/2024	SIGNATURE: 	

Formwork and Falsework

To be done safely, each of these jobs requires planning, knowledge, and skill from both supervisors and workers. Design and planning are a supervisory function that may also legally require a professional engineer's involvement. Small construction and renovation jobs, however, sometimes call for typical design work (e.g., specific heights and sizes from the manufacturer), which can be done on site by workers.

Where design drawings are provided, it is important to construct the formwork as designed. Any confusion regarding the design must be approved by the designer.

If site conditions require changes or the design does not seem to suit the situation, changes and approval must also be obtained from the designer. Formwork failures frequently involve deviations from the original design that were done without consulting the designer. They may also involve human error. For these reasons, formwork and shoring must always be inspected before concrete is placed.

All large formwork installations in Ontario must be designed by a professional engineer. But there are always smaller jobs of moderate height or depth— basements, footings, stairs—that may include formwork with typical design arrangements from a form tie manufacturer, which is installed and constructed on the site.

Every formworker shall therefore know the type of formwork needed and how to build, install, and dismantle it safely.

J-AAR Supervisors will inspect and sign off on all formwork and/or falsework prior to any pour. The inspections will be logged and recorded. Inspections must follow the manufacturer instructions. A letter from an engineer titled "Appointment of a designated competent worker for inspections of falsework/formwork" deems the supervisor as a competent worker.

Formwork must always be constructed according to good, safe, and sound carpentry practice. It must have the following:



- Adequate braces and supports.
- Reliable bearing surfaces, especially where wood structures are involved.
- Adequate ties, bolts, or bracing to prevent movement or bulging.

Because wood is relatively soft, it will crush under heavy loads such as concrete when the bearing surface of joists on stringers, or studs on wales, is not adequate.

Crushing can be avoided by increasing the bearing area between members, using spreader washers, or increasing the number of joists or studs.

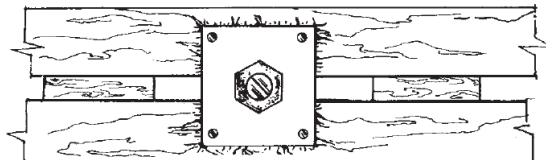
Spreader Washer on Wooden Wale System



 <p>HEALTH, SAFETY & ENVIRONMENTAL MANUAL</p>	11.6 Formwork and Falsework Program				
	Initial HIRA Score:	15	Residual HIRA Score:	10	Critical Task: Yes
	Procedure(s): 12.11.6				
	Revision Number: R0		Number of Pages: 27		
	Revision Date:	Approval Date: 10/01/2024	Effective Date: 10/01/2024	SIGNATURE: 	

Formwork and Falsework

Hazards

The following are the main hazard areas in formwork operations:

Falls – They are the major hazard because they are potentially fatal. Cramped work areas, inadequate access, failure to install guardrails, failure to use fall arrest systems, tools or material left underfoot, and surfaces slippery from form oil can all lead to falls. Ladders are also frequently involved in falls. All workers in Ontario who may be exposed to a fall hazard and who may use a fall protection system must have working at heights training that has been approved by the Chief Prevention Officer.

Materials Handling – The activity most frequently connected with injury. Improper or excessive materials handling can result in sprains, strains, and overexertion in shoulders, arms, and back, as well as bruises, abrasions, and crushed fingers.

Struck Against – Common because formwork operations are constantly changing and involve the movement of heavy, awkward, and pointed components. Wales, beams, panels, snap-ties, nails, bolts, and rebar can cause punctures, cuts, contusions, and abrasions.



Struck By – Another common cause of injury. Rebar, formwork panels, concrete buckets, and other material hoisted overhead can strike workers. Struck-by injuries can also be caused by hammers, pry bars, stakes, wedges, and material such as joists and panels during stripping.

Electrical Contact – Power tools, extension cords, and temporary supply and wiring systems, used under less-than-ideal conditions – mud, ground water, wet excavations, fresh concrete – can lead to ground faults, short-circuits, and shock hazards. Ground fault circuit interrupters are legally required for portable tools used outdoors or in wet locations.

Collapses – Even with advanced methods of design and installation, there is always the risk that formwork, slab forms, wall forms, and other large components can come loose, slip out of place, or fall over, striking or crushing workers underneath.

Health Hazards – The spraying of form oils and curing compounds can irritate the lungs. Contact with these chemicals can irritate the skin, leading to redness, inflammation, or dermatitis. The same conditions can result from the abrasive/ corrosive effect of skin contact with concrete or cement, especially when inadvertently left inside boots all day.

Environmental Conditions – Ice, snow, and rain create slippery conditions. Wind can be a major hazard. Handling sheets of plywood becomes more difficult, panels may require more bracing, and hoisting gets harder, especially with large panels or tables.

 <p>HEALTH, SAFETY & ENVIRONMENTAL MANUAL</p>	11.6 Formwork and Falsework Program				
	Initial HIRA Score:	15	Residual HIRA Score:	10	Critical Task: Yes
	Procedure(s): 12.11.6				
	Revision Number: R0		Number of Pages: 27		
	Revision Date:	Approval Date: 10/01/2024	Effective Date: 10/01/2024	SIGNATURE: 	

Formwork and Falsework

Dust and Concrete – Blowing dust and flying concrete particles during the chipping or cleaning of formwork can injure unprotected eyes.

Access Equipment – Access equipment such as ladders and scaffolds are involved not only in falls but in slips, trips, and other accidents. Hazards include ladders not tied off, workers carrying materials while climbing, ladders obstructed at top or bottom, scaffolds not completely decked in, and scaffolds erected or dismantled without fall protection.

Lighting – Inadequate lighting can create or aggravate hazards when workers install or strip forms in dark areas or place concrete at night.

Injuries

Formwork hazards can lead to the injuries described below. Follow safety tips to prevent such injuries:

Eye Injuries – These are quite common in formwork operations. Most result from particles of wood or concrete that fall or are blown into the eye during chipping and cleaning. The injuries may not be severe but most can be prevented by wearing eye protection. It is strongly recommended that everyone on site wear eye protection at all times.



Cuts, Scrapes, Punctures – The manhandling necessary to install and strip formwork can lead to cut hands, arms, and legs, as well as pinched or crushed fingers. Gloves help to prevent injuries from rough or sharp edges on formwork components. But workers must also have the knowledge, skill, and physical ability necessary for safe materials handling. That means knowing your limitations and asking for help when needed.

Formwork involves protruding objects such as nails, snap ties, conduit, and bolts that can give you cuts and punctures. Where possible, these objects will not be left sticking out or will be covered over.

Back Injuries – These injuries are frequently related to materials handling. The most important preventive measure is back care. Exercise programs, warm-ups before work, and knowing your limitations can help to prevent sprains and strains. Wherever necessary, get help or use dollies, carts, or other mechanical devices.

Ankle Sprains and Fractures – Working in close quarters, stepping over debris and material, climbing into excavations, turning with awkward loads, jumping down from scaffolds or benches—these can lead to ankle and other foot or leg injuries. Prevention starts with proper housekeeping and materials handling.

Bruises and Contusions – Handling formwork under rushed, cramped, or slippery conditions or beyond a person's physical limitations can lead to bruises. Bruises and contusions also result from contact with protruding formwork components. More serious are contusions from falling formwork materials. Formwork

 <p>HEALTH, SAFETY & ENVIRONMENTAL MANUAL</p>	11.6 Formwork and Falsework Program				
	Initial HIRA Score:	15	Residual HIRA Score:	10	Critical Task: Yes
	Procedure(s): 12.11.6				
	Revision Number: R0		Number of Pages: 27		
	Revision Date:	Approval Date: 10/01/2024	Effective Date: 10/01/2024	SIGNATURE: 	

Formwork and Falsework

must be braced to ensure stability, especially under windy conditions. Try to avoid areas where work such as hoisting or stripping is being done overhead.

Fall Injuries – All of the injuries above, and many others, can result from falls. Most falls are caused by missing or inadequate guardrails, failure to use fall-arrest equipment, failure to completely plank scaffolds and other work platforms, and standing or climbing on surfaces not meant to be used as such – the tops of wall forms or 2 x 4 wales, for example. Installing and stripping formwork often requires the use of a fall-arrest system. Falls also result from holes left unguarded or uncovered in formwork. These shall be covered up or fitted with guardrails as quickly as possible. Where this cannot be done, the area must be roped off and posted with warning signs to prevent unauthorized entry.

Planning

Planning is the first and most important step in reducing hazards and preventing injuries. Because formwork operations must often be carried out in congested areas where other trades are also working, planning is essential in making the most of the time and space available to improve safety and efficiency.

Planning is a must for fall protection, work platforms, material staging areas, housekeeping, and material handling and movement.

Planning will take place at every level from manager to supervisor to worker. Planning labour, materials, equipment, and work schedules to meet design requirements is the responsibility of management and supervision. But supervisors and workers shall come together to plan the details of their assigned tasks based on the most effective work methods and safety measures.

Design



Safety and economy are the main factors in design. Both have to be considered because adjustments in one affect the other.

For example, reducing the support structure for wall forms in expectation of reduced pouring rates will not be considered if the rate of pour is not going to be controlled on the job.

Fresh concrete exerts a pressure on formwork similar to liquids. Concrete starts to set when poured. So if the pour rate is slow, the maximum formwork design pressure can be reduced, since concrete at the bottom will be set before concrete at the top is poured.

Similarly, if the forms are filled to the top immediately, they must be able to withstand the pressure of the full liquid head.

For example, the normal weight of liquid concrete is 150 lb per cubic foot (2,403 kg per cubic metre). So a form designed to withstand 600 lb per square feet (2929 kg per square metre) of pressure will be able to support liquid concrete up to a height of 4 feet (1.2 metres).

 <p>HEALTH, SAFETY & ENVIRONMENTAL MANUAL</p>	11.6 Formwork and Falsework Program				
	Initial HIRA Score:	15	Residual HIRA Score:	10	Critical Task: Yes
	Procedure(s): 12.11.6				
	Revision Number: R0		Number of Pages: 27		
	Revision Date:	Approval Date: 10/01/2024	Effective Date: 10/01/2024	SIGNATURE: 	

Formwork and Falsework

$$600 \text{ lb/ft}^2 \div 150 \text{ lb/ft}^3 = 4 \text{ ft}$$

$$2929 \text{ kg/m}^2 \div 2403 \text{ kg/m}^3 = 1.2 \text{ m}$$

Other factors determine how long concrete will remain liquid, such as temperature, slump, vibration, and admixtures. For example, concrete will set much more quickly in hot summer weather than in cold winter weather. As a result, the same form filled at the same pour rate may be subjected to greater pressure in winter than in summer.

Concrete pumping may cause additional pressure, as well as vibration, on forms and must be considered at the design stage. The action of the pump sends surges of pressure through the piping system which are often transmitted directly to the forms, especially for narrow walls or columns. Vibration may move the forms or loosen bracing, ties, or spreaders.

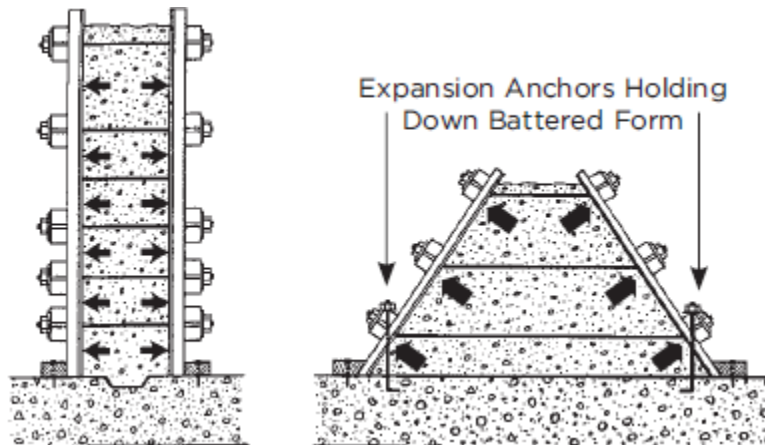

Pressure acts perpendicular to formwork surfaces. This causes an outward thrust for typical wall or column forms. However, it can also cause uplift for battered or sloping forms. These require hold-down anchors or tie-down braces. The anchors will prevent the forms from lifting up or floating on the concrete.



Pressure of Concrete on Vertical and Battered Formwork

Consider using bracing systems and spreaders for wall forms. Concrete filling the bottom of the form may cause forces at the top to push the two sides together unless they are properly braced and/ or separated with spreaders. Formwork has to be designed to resist such forces. During pouring, ensure that spreaders are not removed until concrete has reached at least two-thirds of the form height.

Where box forms are used—for instance, on one-piece covers for open-cut tunnels—you must use bracing

 HEALTH, SAFETY & ENVIRONMENTAL MANUAL	11.6 Formwork and Falsework Program				
	Initial HIRA Score:	15	Residual HIRA Score:	10	Critical Task: Yes
	Procedure(s): 12.11.6				
	Revision Number: R0		Number of Pages: 27		
	Revision Date:	Approval Date: 10/01/2024	Effective Date: 10/01/2024	SIGNATURE: 	

Formwork and Falsework

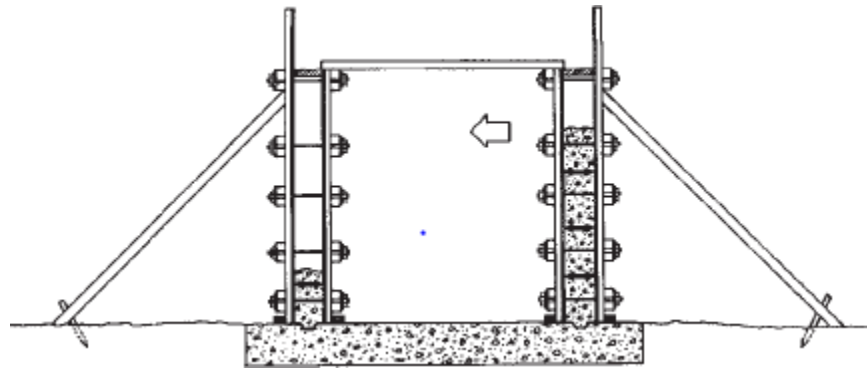

against the side thrusts caused by the uneven pouring rates of the walls. Resisting these forces requires that the system be tied together and securely braced.

Open-Cut Tunnel Formwork with Bracing and Spreaders on Each Side

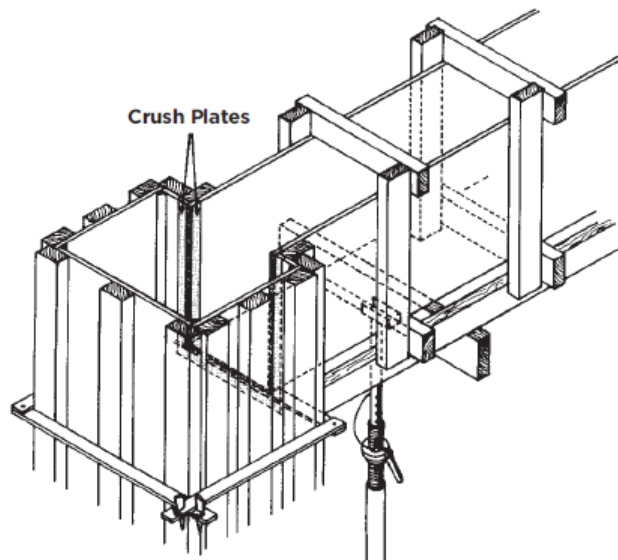

Formwork shall be designed and constructed with stripping and removing as well as pouring in mind. On wooden forms, crush plates or filler strips must be used at corners such as slab-and-column or slab-and-wall intersections. The plates or strips are easily removed with a wrecking bar and once removed, make the stripping of adjacent panels much easier.



 HEALTH, SAFETY & ENVIRONMENTAL MANUAL	11.6 Formwork and Falsework Program				
	Initial HIRA Score:	15	Residual HIRA Score:	10	Critical Task: Yes
	Procedure(s): 12.11.6				
	Revision Number: R0		Number of Pages: 27		
	Revision Date:	Approval Date: 10/01/2024	Effective Date: 10/01/2024	SIGNATURE: 	

Formwork and Falsework

The strips must be big enough to leave space at the edges of the panels to accommodate wrecking bars.

When formwork has to be manhandled during assembly or dismantling, the design must ensure that the components are manageable. Formwork panels are not only heavy but awkward. Realistic design demands consideration of the size as well as the weight of panels.

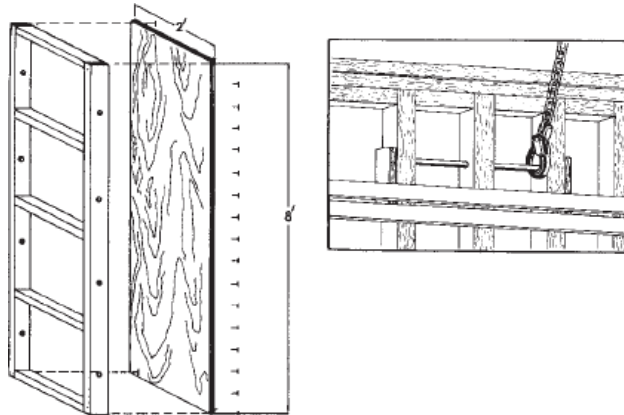

Formwork Panel

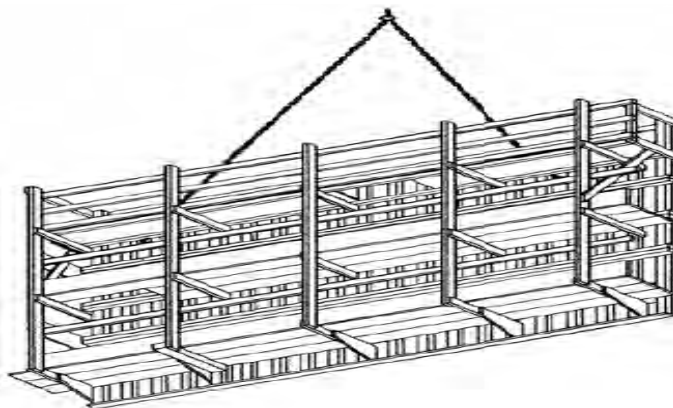

A formwork panel or wall form to be lifted as a single unit must be designed to withstand the loads and forces exerted by hoisting. In most cases, this means designing a more substantial structure. Fastening components may also need more attention at the design stage. For example, simple nailing may not be enough to hold plywood sheets.

Formwork Lifted as Single Unit



 HEALTH, SAFETY & ENVIRONMENTAL MANUAL	11.6 Formwork and Falsework Program				
	Initial HIRA Score:	15	Residual HIRA Score:	10	Critical Task: Yes
	Procedure(s): 12.11.6				
	Revision Number: R0		Number of Pages: 27		
	Revision Date:	Approval Date: 10/01/2024	Effective Date: 10/01/2024	SIGNATURE: 	

Formwork and Falsework

Special attention must also be applied to the design, construction, and use of pick points for hoisting. The strongbacks and wales must be securely attached to the formwork. The pick points must be located so that the panel hangs properly during installation, concrete placement, and removal.

Types of Formworks

Below Grade

The first concern with formwork below grade is the stability of the excavation walls. Walls must be either shored or sloped according to soil type as defined by section 226 of the Construction Projects regulation (O. Reg. 213/91). Below shows typical slopes.

Excavation Slopes for Soil Types

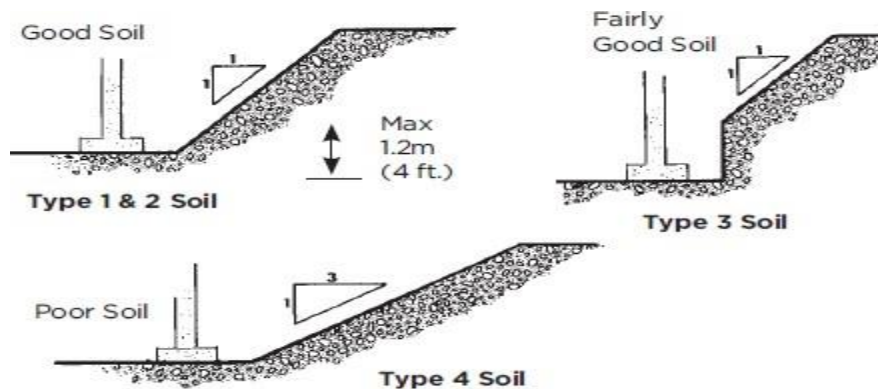



In most cases the shoring must be designed by an engineer. Engineers may also specify slopes for excavations. In both instances the design drawings must be kept on the project.

Excavations must be kept essentially dry. Water will be pumped out. Mud will be cleared off and replaced by compacted granular material in work areas and on surfaces where concrete will be placed. Mud presents slipping hazards and can lead to inferior construction if not removed or replaced.

Since mud has to be removed before concrete is placed, it might as well be removed before formwork is constructed, thereby reducing slipping hazards at both stages.

Water and mud also contribute to electrical hazards. Grounding and insulation must be effective and intact. Ground fault circuit interrupters (GFCIs) are required by law on all portable tools used outdoors or in wet locations.

Formwork for footings and grade walls frequently begins before excavation in the area is complete. Trucks and excavating equipment put workers on foot at the risk of being struck down or run over.

 HEALTH, SAFETY & ENVIRONMENTAL MANUAL	11.6 Formwork and Falsework Program				
	Initial HIRA Score:	15	Residual HIRA Score:	10	Critical Task: Yes
	Procedure(s): 12.11.6				
	Revision Number: R0		Number of Pages: 27		
	Revision Date:	Approval Date: 10/01/2024	Effective Date: 10/01/2024	SIGNATURE: 	

Formwork and Falsework

Wherever possible, formwork operations will be roped off from other work such as excavation or pile-driving. Separate access ramps for vehicles and workers are strongly recommended. Stairs are an even better alternative for personnel on foot.

Formwork Roped-Off from Other Operations

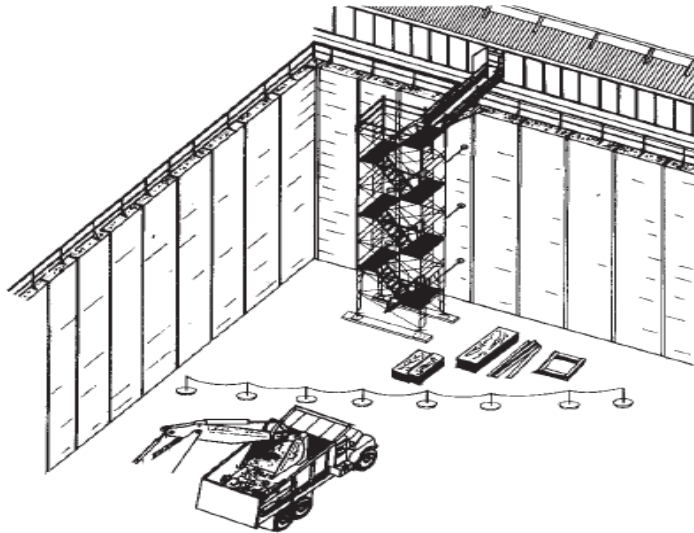

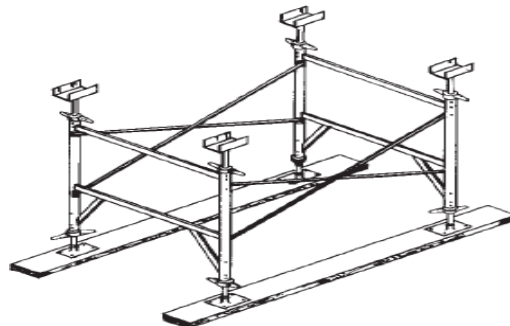

Mud sills must be used to support any shoring or bracing that rests on soil in the excavation. The sill must bear on the soil throughout its length. Sills must not be used to bridge holes or irregular surfaces. To ensure uniform bearing, soil will be levelled before sills are set in position.

Mud Sills Under Shoring Forms



The soil must have the capacity to bear whatever loads are applied (Table 42-1). This information may or

 HEALTH, SAFETY & ENVIRONMENTAL MANUAL	11.6 Formwork and Falsework Program				
	Initial HIRA Score:	15	Residual HIRA Score:	10	Critical Task: Yes
	Procedure(s): 12.11.6				
	Revision Number: R0		Number of Pages: 27		
	Revision Date:	Approval Date: 10/01/2024	Effective Date: 10/01/2024	SIGNATURE: 	

Formwork and Falsework

may not be on the design drawings.

Table 42-1: In Situ Bearing Pressure for Dry Soil Conditions (Conservative Estimates)	
Silt and clay	1,200 lb/ft ² (5,859 kg/m ²)
Sands	4,000 lb/ft ² (19,530 kg/m ²)
Gravelly sands	6,000 lb/ft ² (29,295 kg/m ²)
Gravel	8,000 lb/ft ² (39,059 kg/m ²)

Soil that supports bracing or shoring must be compacted and qualify as good soil at least (cohesive, hard, with no water). Professional advice from a geotechnical engineer may be required for heavy structures such as elevated equipment supports shored at or below grade.

Formwork in these situations is frequently built in place. Planning is required to store material and equipment out of the way, dispose of scrap and debris, and ensure safe, efficient access. Because conditions are often cramped and scrap accumulates quickly, it is important to clean up as work proceeds.

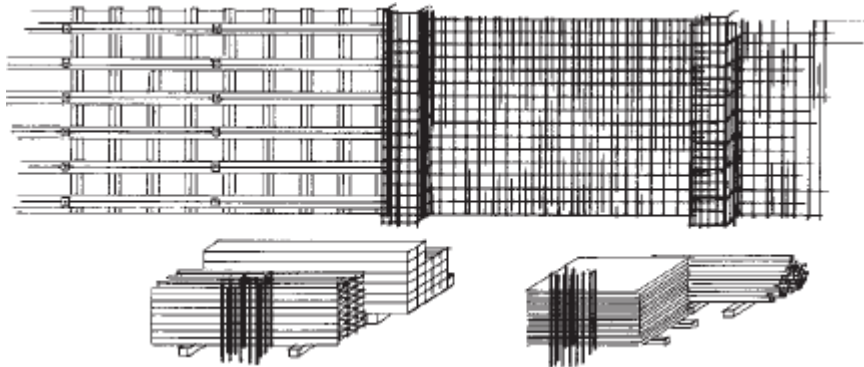

Well Planned Storage, Access, and Setup



Wall Forms

Wall forms built in place are hazardous to construct. Hazards include:

- Dowels sticking up from concrete slabs or footings
- Unstable work surfaces and access created by poor planning
- Manual handling of heavy material such as plywood sheets, panels, wales, and buckets of snap ties, wedges, and plates

 HEALTH, SAFETY & ENVIRONMENTAL MANUAL	11.6 Formwork and Falsework Program				
	Initial HIRA Score:	15	Residual HIRA Score:	10	Critical Task: Yes
	Procedure(s): 12.11.6				
	Revision Number: R0		Number of Pages: 27		
	Revision Date:	Approval Date: 10/01/2024	Effective Date: 10/01/2024	SIGNATURE: 	

Formwork and Falsework

- Slippery surfaces at and below grade
- Inadequate design
- Improper construction.

The best protection against dowels is a wood cover built of lumber at least 1 1/2 inches thick and wired in place or protective caps placed over the exposed ends of rebar.

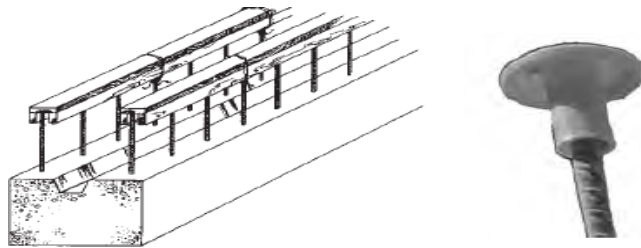

Protective Covers Over Dowels and Rebar



Starting the Form

Setting up the first form is always hard, heavy, manual work. It requires enough workers to do the job without overexertion or injury. Whenever possible, use mechanical assistance such as a boom, truck, or crane for this operation. It will reduce the risk of injury to workers and increase productivity.

Temporary bracing is needed from the start and at every step to prevent wind loads from toppling the forms—historically the cause of many serious injuries. A wind speed as low as 30 km/h can create a dangerous wind load on formwork.

 <p>HEALTH, SAFETY & ENVIRONMENTAL MANUAL</p>	11.6 Formwork and Falsework Program				
	Initial HIRA Score:	15	Residual HIRA Score:	10	Critical Task: Yes
	Procedure(s): 12.11.6				
	Revision Number: R0		Number of Pages: 27		
	Revision Date:	Approval Date: 10/01/2024	Effective Date: 10/01/2024	SIGNATURE: 	

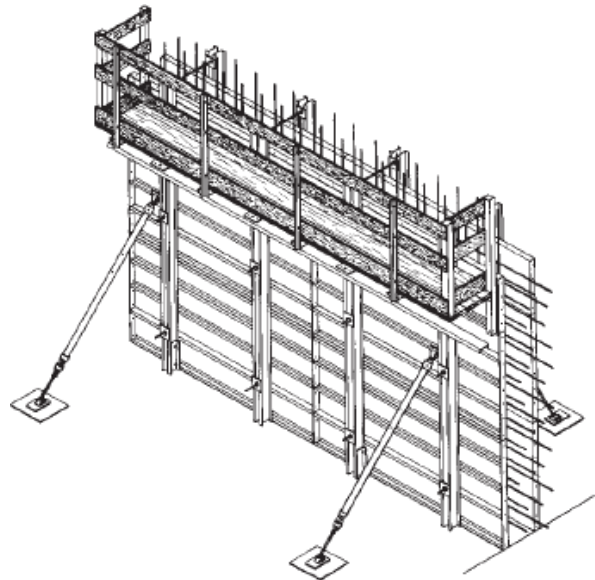

Formwork and Falsework

Temporary Bracing at Start of Form Construction



Access to wall forms is not always given enough thought. Forms more than 2 metres high will require access platforms for workers involved in concrete placing. The platforms can also be used to complete the upper portion of the formwork.

An alternative is a frame scaffold, which can also be used to install reinforcing steel.

 <p>HEALTH, SAFETY & ENVIRONMENTAL MANUAL</p>	11.6 Formwork and Falsework Program				
	Initial HIRA Score:	15	Residual HIRA Score:	10	Critical Task: Yes
	Procedure(s): 12.11.6				
	Revision Number: R0		Number of Pages: 27		
	Revision Date:	Approval Date: 10/01/2024	Effective Date: 10/01/2024	SIGNATURE: 	

Formwork and Falsework Scaffolding for Access

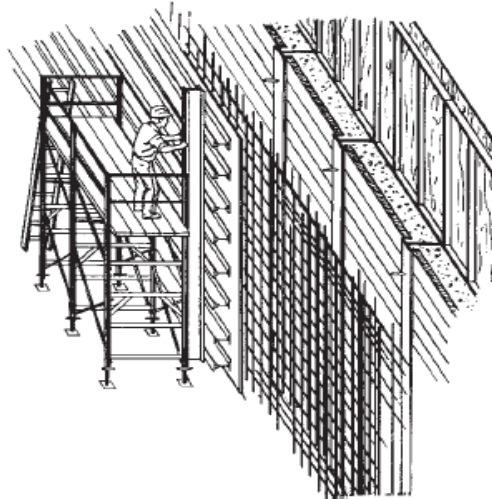

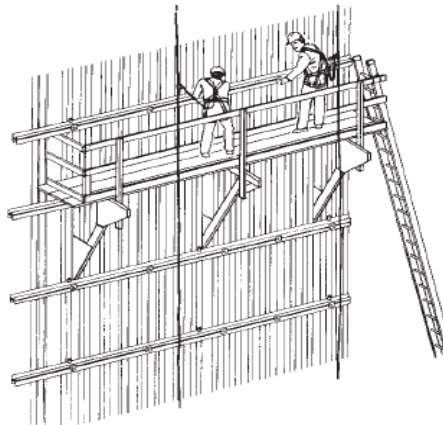

Fall arrest systems or scaffolds with guardrails must be used where workers may fall more than 3 m (10 ft), or onto hazards such as projecting dowels. In some circumstances, you must use fall protection when the height is 2.4 m (8 ft) or more.



Materials shall be distributed along the work location to minimize further handling. But traffic and work areas must be kept clear for the safe movement and installation of material.

Form Construction

Wall forms must be constructed as designed. The design must indicate clearly what is required. Some wall forms are designed for specific concrete placement rates expressed in metres of height per hour (m/hr). A

 <p>HEALTH, SAFETY & ENVIRONMENTAL MANUAL</p>	11.6 Formwork and Falsework Program				
	Initial HIRA Score:	15	Residual HIRA Score:	10	Critical Task: Yes
	Procedure(s): 12.11.6				
	Revision Number: R0		Number of Pages: 27		
	Revision Date:	Approval Date: 10/01/2024	Effective Date: 10/01/2024	SIGNATURE: 	

Formwork and Falsework

wall form in which concrete is placed to a height of one metre in one hour would have a placement rate of 1 m/hr. Slower pouring rates result in lower formwork pressure because the bottom concrete has started to set.

Note: Using a concrete vibrator will increase the liquid (hydraulic) pressure on the form in the immediate area of the vibration. Over-vibrating the concrete while increasing the pour rate can cause the formwork to fail.

Ensure that ties and braces are installed where indicated on design drawings. Ties must be snugged up. Braces will be securely fastened to forms and wedged or fastened to a support that will not settle or deform under load.



Formwork platforms must be:

- Capable of bearing at least 50 lb/ft²
- Adequately supported
- Equipped with guardrails
- Secured at the level or levels where work such as pouring and stripping will be done.

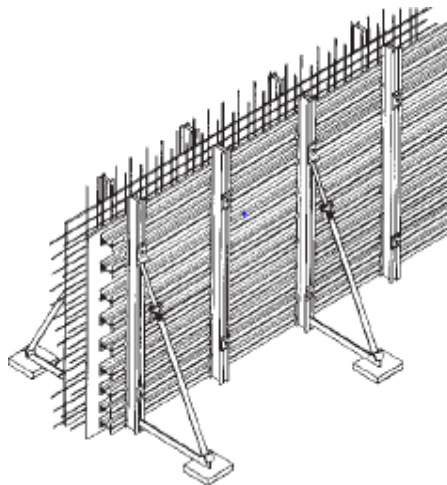
Formwork Properly Tied and Braced



Recommended design pressures for various pour rates and environmental conditions are set out in CAN/CSA S269.1-16: *Falsework and Formwork*. The standard defines a number of other design considerations and should be consulted by field staff.

 <p>HEALTH, SAFETY & ENVIRONMENTAL MANUAL</p>	11.6 Formwork and Falsework Program				
	Initial HIRA Score:	15	Residual HIRA Score:	10	Critical Task: Yes
	Procedure(s): 12.11.6				
	Revision Number: R0		Number of Pages: 27		
	Revision Date:	Approval Date: 10/01/2024	Effective Date: 10/01/2024	SIGNATURE: 	

Formwork and Falsework

Slab Forms or Falsework Built in Place

With slab forms built in place the major hazard is falls. Injuries are also connected with the manual handling of heavy materials and components.

Forms built in place usually have to be taken down in place after the concrete has hardened sufficiently. This must be considered at the construction stage. Stability may also be a consideration where the structure is high, carries heavy loads, and is placed on grade as in bridge and overpass construction.

Fall protection is difficult to provide for workers building slab forms in place. That's why planning is essential in the design and erection procedure.

Workers must wear a safety harness with the lanyard tied off to the structure of the formwork. This means tying off to the support structure where shoring frame structures are being constructed, tying off to a lifeline when placing plywood panels at a leading edge, constructing a guardrail at the edge of the formwork, or tying off to the support structure when connecting it together with tube and clamp. Don't wait for the structure to be completed before tying-off.

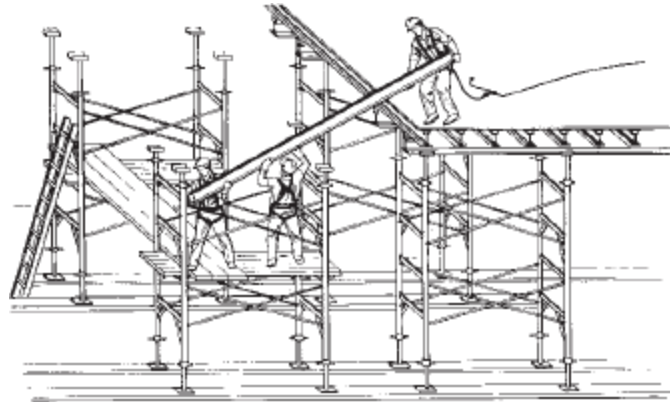

Workers Tie Off to Shoring Frames While Placing Stringers



Make sure you have fall protection at all stages of formwork construction. Wherever possible, cranes or other equipment shall be used to move material, thereby reducing the amount of manual carrying, lifting, and handling.

Shoring towers require special consideration.

- Towers must remain stable during construction and dismantling. Guys or other bracing and supports may be necessary to maintain stability.
- If towers are to be tied together and braced horizontally, this will be done as work progresses.

 HEALTH, SAFETY & ENVIRONMENTAL MANUAL	11.6 Formwork and Falsework Program				
	Initial HIRA Score:	15	Residual HIRA Score:	10	Critical Task: Yes
	Procedure(s): 12.11.6				
	Revision Number: R0		Number of Pages: 27		
	Revision Date:	Approval Date: 10/01/2024	Effective Date: 10/01/2024	SIGNATURE: 	

Formwork and Falsework

- Shoring towers and shores shall be installed so they are plumb to within 1/8 inch in 3 feet.
- Shoring towers shall be snugged up under the stringers with adjustable base plates and U-heads.
- If frames do not ride tightly on top of one another after tightening, one or more are out of square and must be replaced.
- With single-post shores, provide adequate lateral bracing. Stairwells and balconies are places where horizontal bracing for single-post shoring systems may be required.

High Towers with Guys for Support

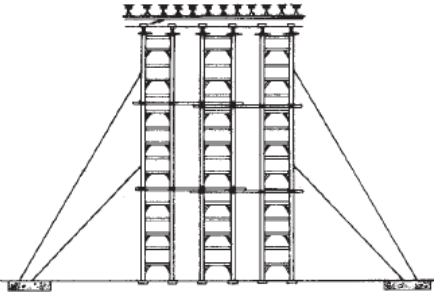

Towers Tied Together and Braced Horizontally

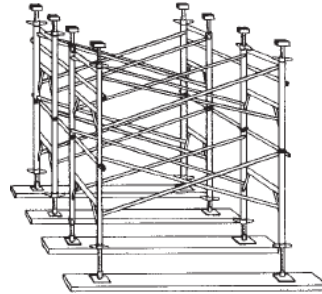



Typical Shoring Tower with Stringers, Adjustable Base Plates, and U-Heads

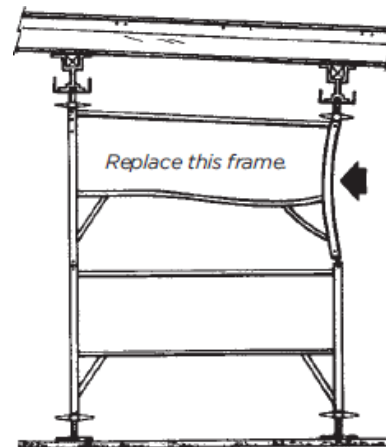

Frame Bent out of Shape



 <p>HEALTH, SAFETY & ENVIRONMENTAL MANUAL</p>	11.6 Formwork and Falsework Program				
	Initial HIRA Score:	15	Residual HIRA Score:	10	Critical Task: Yes
	Procedure(s): 12.11.6				
	Revision Number: R0		Number of Pages: 27		
	Revision Date:	Approval Date: 10/01/2024	Effective Date: 10/01/2024	SIGNATURE: 	

Formwork and Falsework

Single-Post Shores with Lateral Bracing

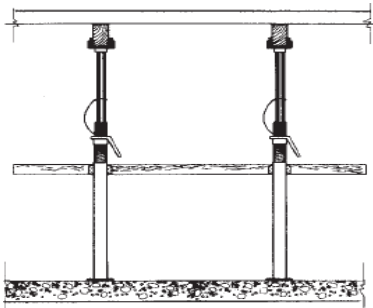

Two Rows of Shoring Frames

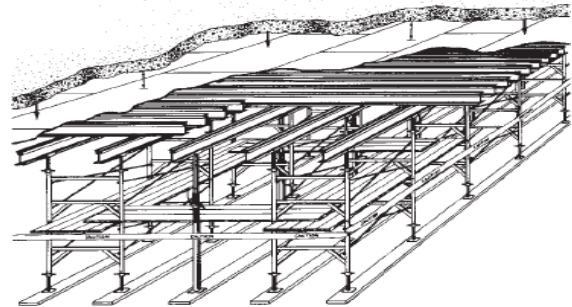



Frequently, supports for built-in-place forms are deliberately left out to allow other work to be done. One example might be a row of single-post shores left out until work below is complete. Or, an area might be supported temporarily during construction by a few single-post shores that will be replaced later by a shoring tower.

In these and other instances of incomplete formwork, heavy temporary loads such as bundles of rebar or stacks of plywood must not be placed on the structure. Even on completed formwork, make sure that landed material will not overload the structure. Before placing concrete, the formwork must be inspected and approved by a professional engineer or their designate. Keep a copy of this inspection and approval on the site in case an inspector asks to see it.

Flying Forms

Flying forms must always be designed by a professional engineer and constructed, hoisted, moved, and set strictly according to the instructions of the designer or manufacturer.



 <p>HEALTH, SAFETY & ENVIRONMENTAL MANUAL</p>	11.6 Formwork and Falsework Program				
	Initial HIRA Score:	15	Residual HIRA Score:	10	Critical Task: Yes
	Procedure(s): 12.11.6				
	Revision Number: R0		Number of Pages: 27		
	Revision Date:	Approval Date: 10/01/2024	Effective Date: 10/01/2024	SIGNATURE: 	

Formwork and Falsework

Using forms designed for typical floors in non-typical situations has resulted in serious accidents. Before using any flying form under non-typical conditions, consult the designer or manufacturer. Wall forms must not be extended in height or width, for instance, or slab panels cantilevered without the review and approval of a professional engineer. Such situations usually occur with penthouses or mechanical rooms where wall and ceiling heights are greater than for typical floors.

Other hazards with flying forms include the following:

- Stability during initial fabrication
- Fill-in work between slab panels
- Wind and fall hazards during flying operations
- Stripping, flying, and re-setting.

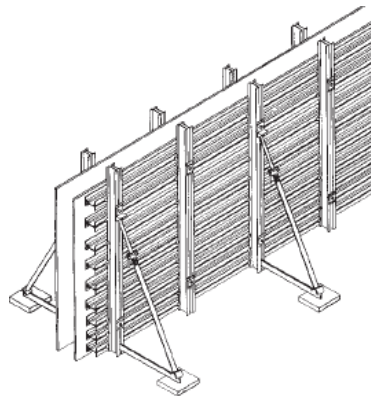

Although a flying form is designed to be stable when complete, it may not be stable during fabrication or erection. Temporary bracing or temporary support by a crane may be necessary to ensure stability during certain phases of the operation.

Temporary Support of Shoring System for Flying Wall Form



One example is setting up trusses for a flying slab formwork table. The trusses must be held upright to be connected or disconnected. If not adequately supported, they can fall over on workers.

Trusses and wall panels have also been blown over by wind during fabrication and dismantling. Set-up procedures shall indicate the maximum wind speed where the flying form operation can be done safely. This wind speed will be determined by the professional engineer who designed the system.

 HEALTH, SAFETY & ENVIRONMENTAL MANUAL	11.6 Formwork and Falsework Program				
	Initial HIRA Score:	15	Residual HIRA Score:	10	Critical Task: Yes
	Procedure(s): 12.11.6				
	Revision Number: R0		Number of Pages: 27		
	Revision Date:	Approval Date: 10/01/2024	Effective Date: 10/01/2024	SIGNATURE: 	

Formwork and Falsework

Work with flying forms requires adequate space for stacking materials and components. Working in cramped quarters is not only difficult but hazardous.

Fall Protection

A fall arrest system must be used by any worker who is at risk of falling when:

- Installing a panel
- Pushing a panel out toward the slab edge
- Pulling a panel in from the slab edge
- Helping other workers attach rigging hardware such as slings
- Getting on and off
- Bolting and unbolting wall forms for exterior walls and elevator shafts
- Stepping onto a panel to attach slings to pick points



Fall Protection Required when Receiving a Flying Form

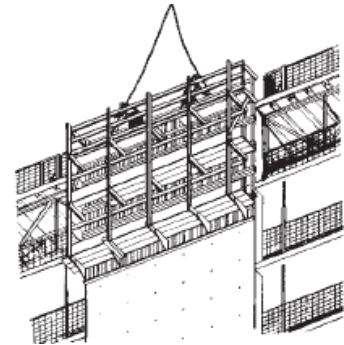
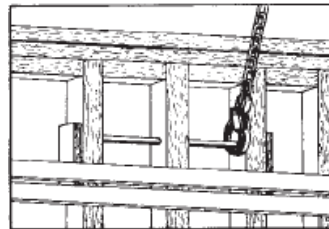

Attaching Chain Sling to Form



Each worker's fall-arrest system must be attached to an individual anchor independent of the flying form. Contractors can provide for anchorage by casting rebar anchors in columns or other areas to be covered over or filled in later. This type of anchorage must be approved by a professional engineer.

 <p>HEALTH, SAFETY & ENVIRONMENTAL MANUAL</p>	11.6 Formwork and Falsework Program				
	Initial HIRA Score:	15	Residual HIRA Score:	10	Critical Task: Yes
	Procedure(s): 12.11.6				
	Revision Number: R0		Number of Pages: 27		
	Revision Date:	Approval Date: 10/01/2024	Effective Date: 10/01/2024	SIGNATURE: 	

Formwork and Falsework Rebar Anchor Case in Concrete

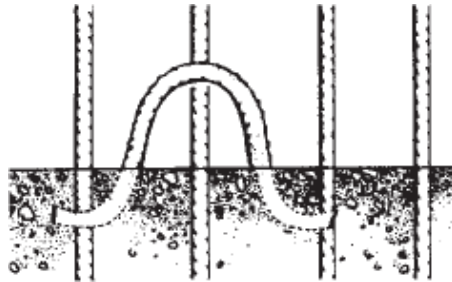

Safety Below Flying Forms

The previous section covered the safety of workers flying the forms. But precautions must also be taken to protect workers below the hoisting operation and the public at large, since forms are often swung out over sidewalks and streets. The Construction Projects regulation (213/91, s. 103(2)) prohibits hoisting a load over the head of a person who is not receiving the load or sinking a shaft.

The most efficient protection for workers is to fence or rope off the area below the flying form to prevent anyone from entering the area. Pedestrian traffic on sidewalks, as well as vehicle traffic if necessary, shall be detoured around the area while hoisting is under way.

Communication

Flying forms are heavy, large, and awkward to move. Hoisting and moving them safely requires clear reliable communication. While hand signals are often necessary and are still used, direct radio or cell phone communication between the signaller and the crane operator is more accurate and effective. Relying on hand signals alone is not recommended.



Stripping

Formwork stripping is probably the most hazardous operation in concrete construction. Hazards include the following.

- Falling material
- Waste material and equipment underfoot
- Manual handling of heavy or awkward forms, panels, and other components
- Prying forms loose from concrete presents risk of overexertion, lost balance, and slips and falls.

Hazards can be reduced by

- Planning and providing for stripping when designing and constructing formwork
- Stripping as soon as it is permitted by the engineer

 <p>HEALTH, SAFETY & ENVIRONMENTAL MANUAL</p>	11.6 Formwork and Falsework Program				
	Initial HIRA Score:	15	Residual HIRA Score:	10	Critical Task: Yes
	Procedure(s): 12.11.6				
	Revision Number: R0		Number of Pages: 27		
	Revision Date:	Approval Date: 10/01/2024	Effective Date: 10/01/2024	SIGNATURE: 	

Formwork and Falsework

- Supplying facilities and equipment for removing materials as they are stripped
- Providing proper tools and adequate access for the stripping crew
- Training personnel properly for this and other aspects of formwork.

Forms can be designed with crush plates or filler strips to facilitate removal at difficult intersections of columns, beams, and wall forms. Later, formwork oils shall be used liberally to make stripping easier.

Wherever possible, waste materials, plywood, and debris will be removed from the area as work proceeds. This will reduce the need to walk over or work around things left on floor or ground.

Providing carts or cradles can help the crew remove material and reduce the need for lifting and carrying. Material on a cart can be rolled away. Material in cradles can be hoisted off by a crane.

Climbing partially stripped formwork is not only hazardous but unnecessary. Safe access such as rolling scaffolds or powered elevating work platforms will be provided for stripping formwork at elevated locations.

Poor lighting may be a hazard in formwork stripping in the early morning or late in the day during certain times of the year. Mobile light stands are probably the best solution, since pigtail stringers can easily be knocked down and damaged during stripping.



Wherever possible, stripping crews shall be small. This is especially important with knock-down systems. In small crews, the supervisor and each worker can more easily keep track of what the others are doing. Workers are not as likely to create hazards for each other. Crews of two or three are recommended for knock-down systems. If more workers are required, they can still be divided into small crews working in separate areas. Other trades and operations must not be allowed in areas where stripping is under way. Given the many hazards involved, the area will be fenced or roped off and warning signs posted.

Knock-Down Slab Systems

Stripping these forms is physically difficult because much of the work is overhead. The usual arrangement involves shoring frames or a combination of shoring frames and jacks.

Wherever possible, the work shall proceed progressively from one side. That means taking out one row of formwork supported by a row of stringers on shoring frames.

The first step is to back off the adjustable base plates and U-heads in one area, which will in turn lower the stringers, joists, and plywood.

 <p>HEALTH, SAFETY & ENVIRONMENTAL MANUAL</p>	11.6 Formwork and Falsework Program				
	Initial HIRA Score:	15	Residual HIRA Score:	10	Critical Task: Yes
	Procedure(s): 12.11.6				
	Revision Number: R0		Number of Pages: 27		
	Revision Date:	Approval Date: 10/01/2024	Effective Date: 10/01/2024	SIGNATURE: 	

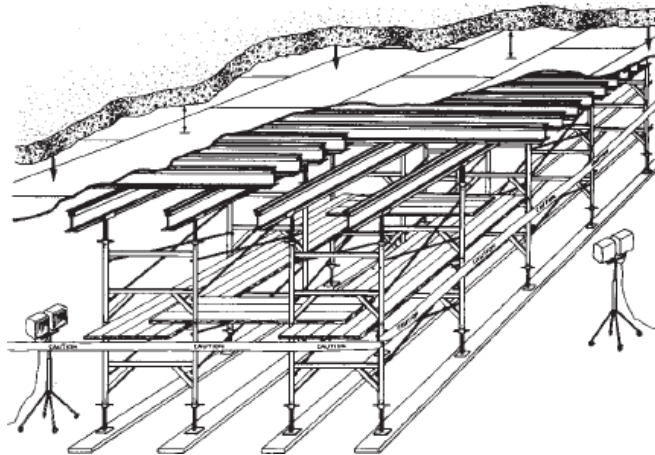

Formwork and Falsework Lowering Base Plates and U-Heads to Release Slab Form



In practice, however, the plywood will stick to the underside of the concrete, especially around beams, column caps, and similar points. Wherever possible, stuck sheets shall be loosened and removed before the shoring structure is dismantled.

Stripping shall proceed in reverse order to erection. Plywood will be removed first, followed by joists and stringers. The last items to be removed are the shoring frames.

When scaffold or shoring frames are used as a work platform, it must be completely decked in with planks. Otherwise, planks can shift and slide as workers pry or pull at stuck pieces of formwork, lose their balance, and fall. This has been a frequent cause of injuries. Temporary guardrails may be required near the edge of the structure or workers will need to use fall protection during this operation.

 <p>HEALTH, SAFETY & ENVIRONMENTAL MANUAL</p>	11.6 Formwork and Falsework Program				
	Initial HIRA Score:	15	Residual HIRA Score:	10	Critical Task: Yes
	Procedure(s): 12.11.6				
	Revision Number: R0		Number of Pages: 27		
	Revision Date:	Approval Date: 10/01/2024	Effective Date: 10/01/2024	SIGNATURE: 	

Formwork and Falsework Shoring Frame Pully Planked for Access

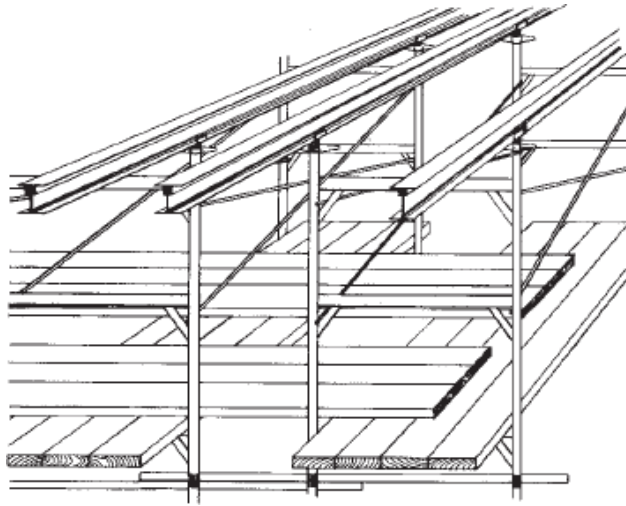

The area where stripping starts must be planned to allow access for taking away material as the form is dismantled.

Sound training, effective supervision, well-designed safe access facilities, and immediate and continuous cleanup can help reduce hazards in stripping knock-down slab forms.

Built-in-Place Wall Forms



These forms are frequently of only moderate height. Taller types usually make use of large panels erected and removed by crane rather than hand. Built-in-place wall forms are usually a stud-and-wale system using some type of formwork ties.

Where workers cannot reach the top of the wall, scaffolding shall be provided for removing wales on the upper level. Safe access is essential for the dismantling and manhandling of wales that are frequently long, heavy, and waterlogged.

Material must then be removed immediately to a staging area.

Inspection

Before concrete placing begins, formwork must be inspected and signed off by a professional engineer or a competent person designated by the engineer to ensure that it has been constructed to provide for worker safety and to meet job specifications.

 <p>HEALTH, SAFETY & ENVIRONMENTAL MANUAL</p>	11.6 Formwork and Falsework Program				
	Initial HIRA Score:	15	Residual HIRA Score:	10	Critical Task: Yes
	Procedure(s): 12.11.6				
	Revision Number: R0		Number of Pages: 27		
	Revision Date:	Approval Date: 10/01/2024	Effective Date: 10/01/2024	SIGNATURE: 	

Formwork and Falsework

A report must be completed by the person doing the inspection stating whether the formwork has been constructed according to the design. Any discrepancies must be approved by the design engineer before concrete placing proceeds.

It is in everyone's best interest to ensure that the formwork has been inspected by a competent person for workmanship, stability, and adherence to design drawings and specifications. Inspection will begin when the forms are being constructed and continue until concrete placing is complete.

Checking line and grade is best carried out while the formwork is being constructed. Shoring structures must be within the alignment limits specified on the design drawings. Line and grade must also be checked during the pour to determine whether formwork is shifting or deflecting.

Dimensions of special features like beams, column capitals, and inserts are best checked at the time of construction. If inspection is delayed until formwork is completed, some details may be covered up or become more difficult to check.

Columns

Check the following:



- The proper size and type of materials are used
- Column ties or column clamps are spaced according to design drawings
- The spacing of ties or clamps is based on a sound assessment of concrete pressure (generally columns are designed for a full liquid head of 150 lb per cubic foot (2,403 kg per cubic metre) times height.
- Columns are adequately braced where they are not tied in to a slab-form structure.

Note: For more information on column formwork pressures, refer to CAN/CSA S269.1- 16: Falsework and Formwork or the American Concrete Institute (ACI) standard Formwork for Concrete (SP-4).

Wall Forms

Check the following:

- Materials and any manufactured components are as specified in design drawings (size and spacing of studs, wales, and ties are crucial to safety)
- Ties are snugged up before concrete is placed
- Wedges in wedged systems are tight
- Nuts in threaded systems are tight
- Bracing conforms to design drawings

 <p>HEALTH, SAFETY & ENVIRONMENTAL MANUAL</p>	11.6 Formwork and Falsework Program				
	Initial HIRA Score:	15	Residual HIRA Score:	10	Critical Task: Yes
	Procedure(s): 12.11.6				
	Revision Number: R0		Number of Pages: 27		
	Revision Date:	Approval Date: 10/01/2024	Effective Date: 10/01/2024	SIGNATURE: 	

Formwork and Falsework

- Free-standing formwork is braced to ensure stability and resistance to loads during concrete placing
- Specified pour rates are not exceeded (wall forms are often designed for specific pour rates; exceeding these rates can cause failure or collapse).

Slab Forms

From a safety perspective, this is the most critical type of formwork. The collapse of slab forms has caused many injuries and deaths, whether from flawed design (e.g., not considering the effect of wind loading on the design), unauthorized modifications in the field, or the failure to inspect, which would have located and corrected deficiencies.

Competent inspection demands knowledge, experience, and the ability to:



- Distinguish between similar but different materials and shoring equipment
- Read and interpret design drawings
- Identify and clear up with the designer any apparent or real discrepancies in components such as shoring frames.

Check the following:

- Grade beams or mud sills supporting shoring are properly sized and located.
- Hazardous soil conditions such as excessive moisture, freezing, and uncompacted soil conditions are reported and discussed with the professional engineer.
- Shoring frames and jacks are located and aligned within tolerances specified on the drawings.
- Shoring frames and jacks are out of plumb no more than 1/8 inch every 3 feet.
- Adjustable base plates for shoring frames and jacks are snugged up.
- U-heads are wedged in place.
- Stringers are the specified size and number, with supports properly spaced.
- Aluminum stringers have no bent flanges or other damage.
- Joists are the specified size and properly spaced.
- Support structures and shoring for beam bottoms and column capitals are constructed according to design.
- Lateral bracing is provided where required (for instance, on freestanding formwork for bridges and overpasses).
- The bearing surface for lateral bracing is adequate—that is, stable footings or well- compacted soil.
- Temporary loads such as rebar are not overloading the system.

Concrete Placing

Forms shall continue being observed during concrete placing. Any signs of movement, crushing, cracking, or deflection are cause for alarm. Placing concrete must be suspended until the situation is corrected.

 HEALTH, SAFETY & ENVIRONMENTAL MANUAL	11.6 Formwork and Falsework Program				
	Initial HIRA Score:	15	Residual HIRA Score:	10	Critical Task: Yes
	Procedure(s): 12.11.6				
	Revision Number: R0		Number of Pages: 27		
	Revision Date:	Approval Date: 10/01/2024	Effective Date: 10/01/2024	SIGNATURE: 	

Formwork and Falsework

Watch for the following warning signs:

- Lateral displacement or movement of single-post shoring for slab forms
- Movement or deflection of lateral bracing for single-post shores
- Movement of stringers on U-heads
- Crushing of wooden stringers on U-heads (Figure 42-29)
- Gaps or shoring that is not snugged up under stringers
- Deflection of stringers between supports (Figure 42-30)
- Deflection of wales or strongbacks on wall forms
- Wall forms that are bulging or cracking
- Crushing of wales or strongbacks at washers for ties
- Movement of wall forms
- Uplifting of battered forms
- Pour rates that exceed design specifications.

Crushing of Stringer Over U-Head

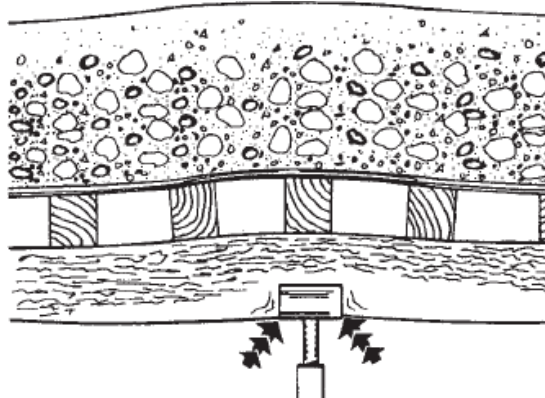

Deflection of Stringers Between Supports

